

Blue Sky Interlocking Playground Tile - Product Guide Specifications

PART 1 GENERAL

1.1 SECTION INCLUDES

- A. Resilient, Interlocking, Blue Sky Playground Turf Lock Tiles.

1.2 REFERENCES

- A. ASTM F 1292 – 04 – Standard Specification for Impact Attenuation of Surface Systems Under and Around Playground Equipment.

1.3 SUBMITTALS

- A. Submittal Procedures.
- B. Product Data: Submit manufacturer's product data, including installation and/or subsurface recommendations.
- C. Samples: Submit manufacturer's sample of 1 full tile
- D. Warranty: Submit manufacturer's standard warranty.

1.4 QUALITY ASSURANCE

- A. Installer's Qualifications:
 - 1. Installers must have successful experience in installation of playground safety surfacing tiles of similar type to that specified, with a minimum of 20 projects completed within last 5 years.
 - 2. Employ persons trained for installation of playground safety surfacing tiles and are approved by manufacturer

1.5 DELIVERY, STORAGE, AND HANDLING

- A. Delivery: Deliver materials to site in manufacturer's original, unopened containers and packaging, with labels clearly identifying product name and manufacturer.
- B. Storage:
 - 1. Playground Safety Surfacing Tiles:
 - a. Store tiles in a dry area prior to installation.
 - b. Protect tiles from direct sunlight before installation.
 - 2. Adhesive: Store adhesive in a dry area at a minimum temperature of 40 degrees F.
 - a. Handling: Protect materials during handling and installation to prevent damage.

1.6 ENVIRONMENTAL REQUIREMENTS

- A. Air Temperature: The air temperature should be a minimum of 40 degrees F for a minimum of 12 hours before and during installation.

Blue Sky Interlocking Playground Tile - Product Guide Specifications

1.7 WARRANTY

- A. Blue Sky Interlocking Playground safety surfacing tiles offer a 10 year limited, prorated warranty. Please contact our Customer Service for additional warranty details.
- B. Performance: Playground safety surfacing tiles shall be warranted to meet drop height performance requirements of ASTM F 1292.

PART 2: PRODUCTS

2.1 DISTRIBUTOR

Greatmats.com 117 Industrial Ave, Milltown, WI 54858
PH#877-822-6622 Fax 866-895-5550
Email: info@greatmats.com
Web: www.greatmats.com

2.2 PLAYGROUND SURFACING TILES

- A. Tiles: Blue Sky Playground Tile.
 - a. Thicknesses 1.5 inches to 3.75 inches.
 - b. Weight: 24 to 34 pounds.
 - c. Colors: Green, Terra Cotta, Brown, Black, Gray, Blue, Beige or EPDM

2.3 ACCESSORIES

- A. Corners Transitions
 - a. Prefabricated outside and inside corners.
 - b. Material: Same as playground safety surfacing tiles.
- B. Ramps:
 - a. Prefabricated Ramps:
 - b. Prefabricated ADA-Compliant Ramps:
 - c. Material: Same as playground safety surfacing tiles.
- C. Edging:
 - a. Prefabricated Curb Edging:
 - b. Material: Same as playground safety surfacing tiles.
- D. Adhesive: Mastic
 - a. Material - MSDS

PART 3: EXECUTION

3.1 EXAMINATION

- A. Examine areas to receive playground safety surfacing tiles. Notify responsible parties if areas are not acceptable. Do not begin installation until unacceptable conditions have been corrected.

Blue Sky Interlocking Playground Tile - Product Guide Specifications

3.2 PREPARATION

- A. Prepare subsurface in accordance with manufacturer's instructions to ensure proper support and drainage for playground safety surfacing tiles.

Notes: Specify subsurface of granular aggregate, concrete, or asphalt. It is critical that a proper subsurface drainage system be constructed or the tile surface may not stay level and may cause damage to surfacing.

- A. Granular Aggregate Subsurface:
Compacted, granular aggregate subsurface shall be as specified in sub straight procedures; however it is advised to hire a professional.
- B. Concrete Subsurface:
 - a. Concrete subsurface shall be as specified.
 - b. Apply light broom finish.
 - c. Ensure concrete is sound with no loose material.
 - d. Ensure concrete is a minimum of 28 days old.
 - e. Power wash existing concrete in accordance with manufacturer's instructions.
- C. Asphalt Subsurface:
 - a. Asphalt subsurface shall be as specified.
 - b. Ensure asphalt is sound with no loose material or cracks.
 - c. Ensure asphalt is a minimum of 28 days old.
 - d. Power Wash existing asphalt.

3.3 INSTALLATION

- A. Install Blue Sky tiles in accordance with manufacturer's instructions at locations indicated.
- B. Ensure prepared subsurface and tiles are dry and clean.
- C. Layout tile surface in accordance with manufacturer's instructions.
- D. Install tiles in single installation session, if possible.
- E. Apply adhesive in accordance with manufacturer's instructions for tile-to-tile and perimeter tile-to-base installation.

3.4 CLEANING

- A. Remove adhesive spills from playground safety surfacing tiles and equipment.
- B. Clean tiles in accordance with manufacturer's instructions.

3.5 PROTECTION

- A. Protect Blue Sky tiles from foot traffic for a minimum of 12 hours after installation.
- B. Protect completed tiles from damage during construction.

Blue Sky Interlocking Playground Tile Sizes

Weight: 27 lbs.
 Units Per Pallet: 80
 Pallet Weight: 2220 lbs

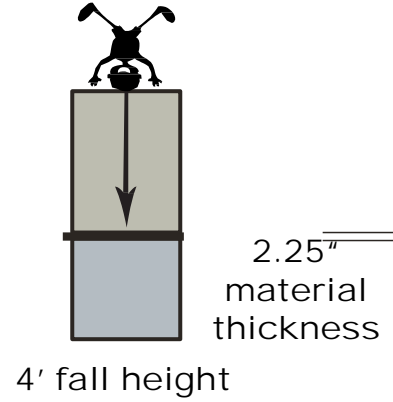
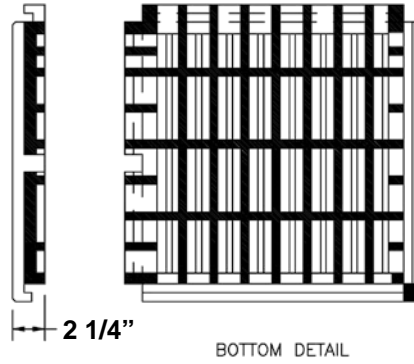
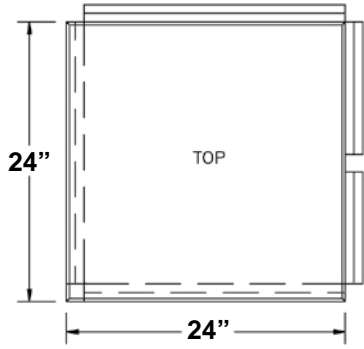

Weight: 30 lbs.
 Units Per Pallet: 60
 Pallet Weight: 1860 lbs

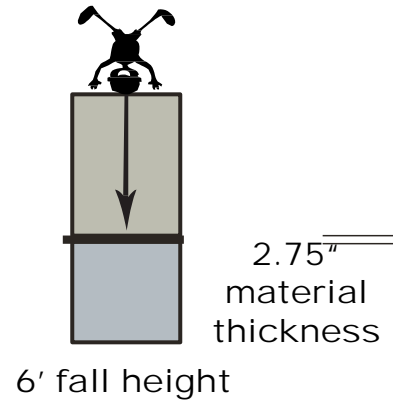
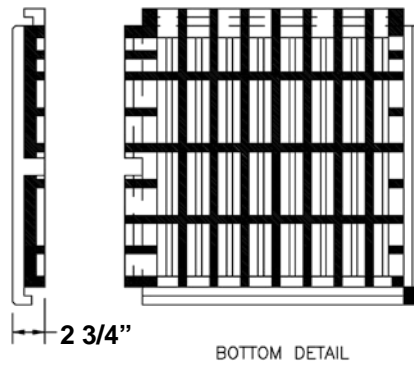
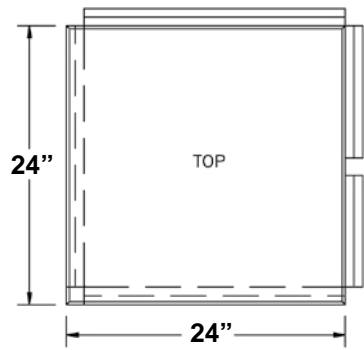

Weight: 32 lbs.
 Units Per Pallet: 60
 Pallet Weight: 1980 lbs

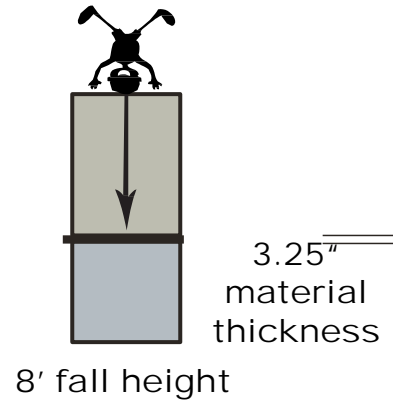
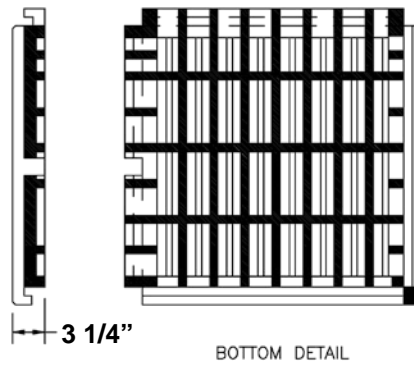
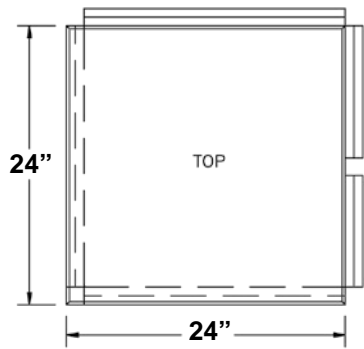

Blue Sky Interlocking Playground

Interlocking Tile - 2.25" (4 foot fall height)

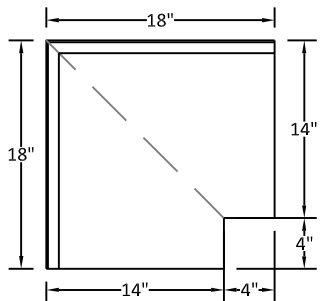

Inside Corner Transition

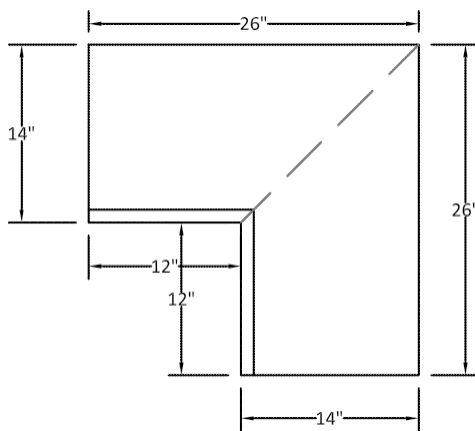

Outside Corner Transition

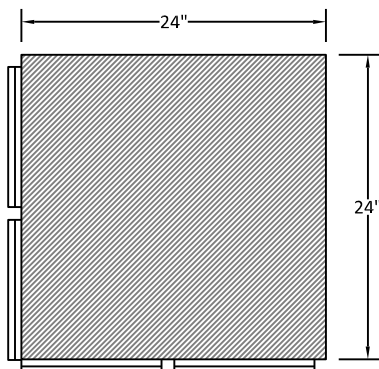

Top View

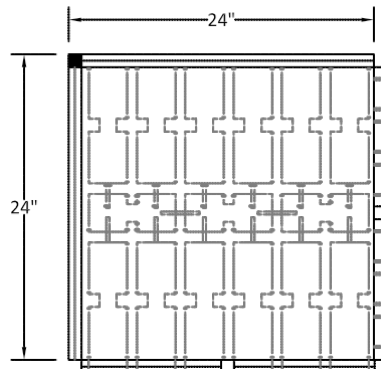

Bottom View



Side View

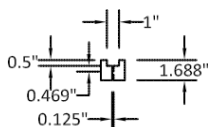

Side View

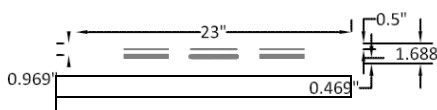

Front View

U Lock Section

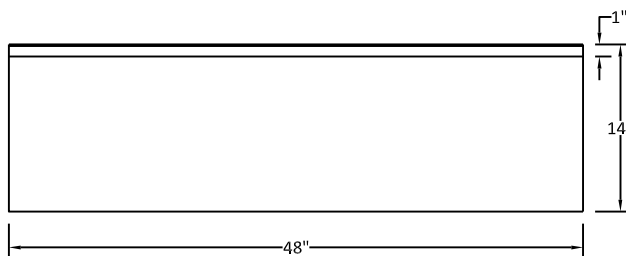
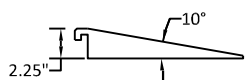

Ramp

Blue Sky Interlocking Playground

Interlocking Tile - 2.75" (6 foot fall height)

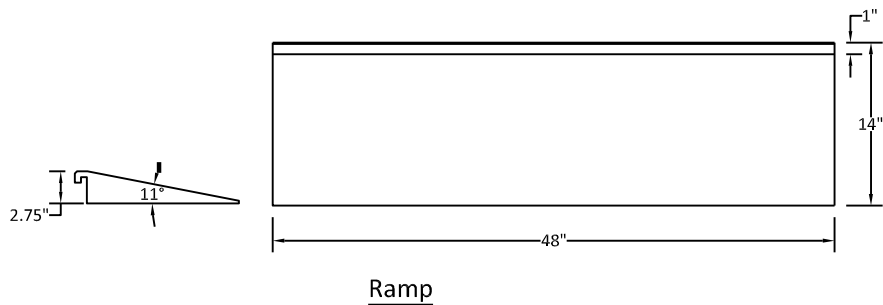
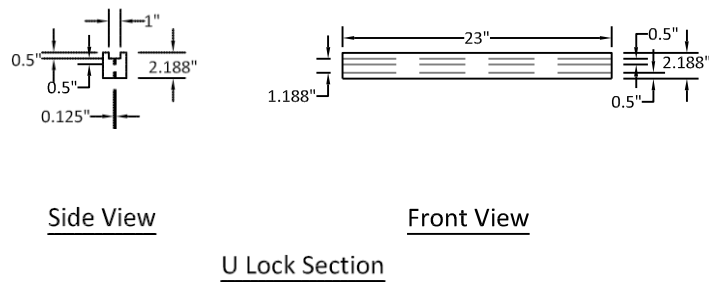
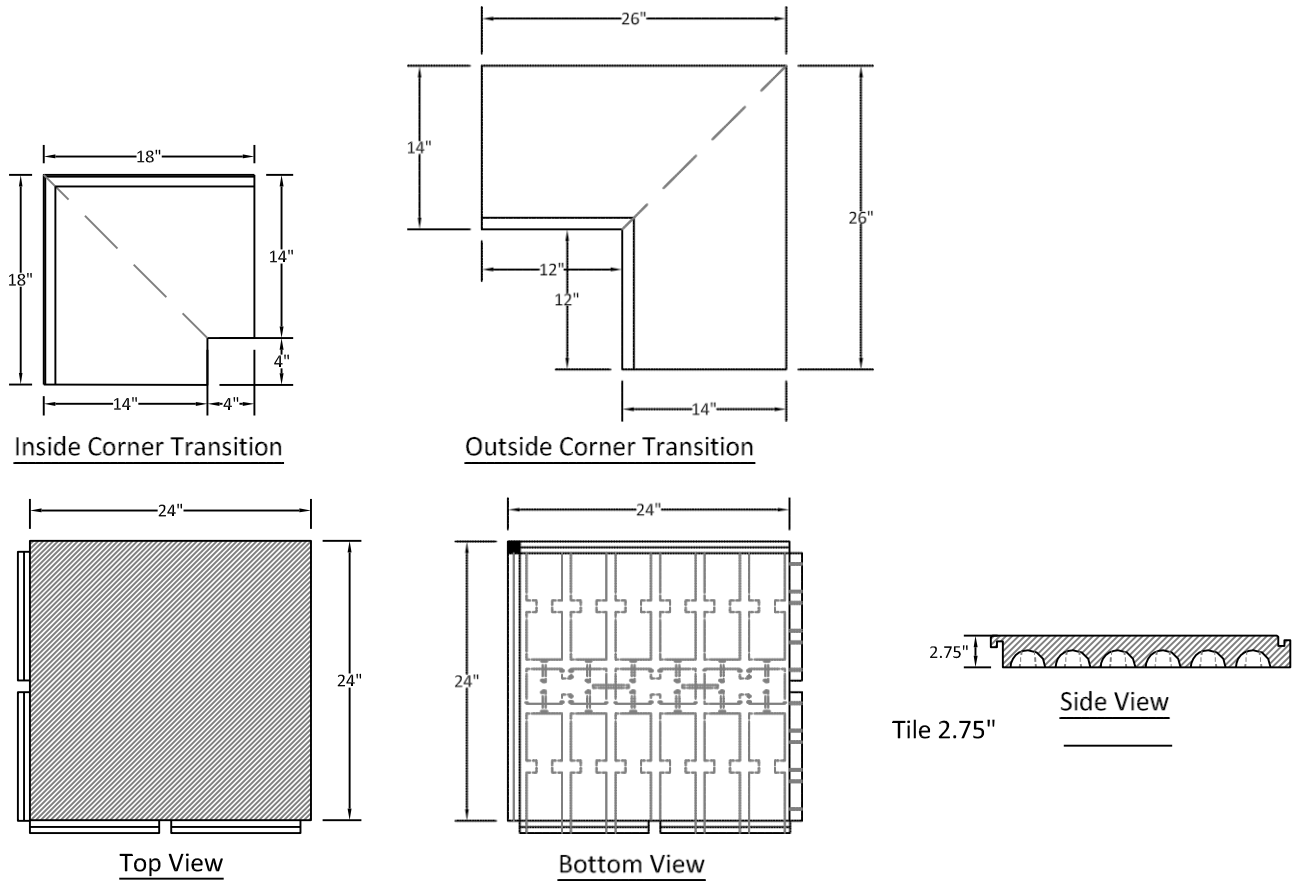

Blue Sky Interlocking Playground

Interlocking Tile - 3.25" (8 foot fall height)

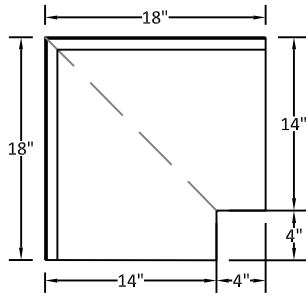

Inside Corner Transition

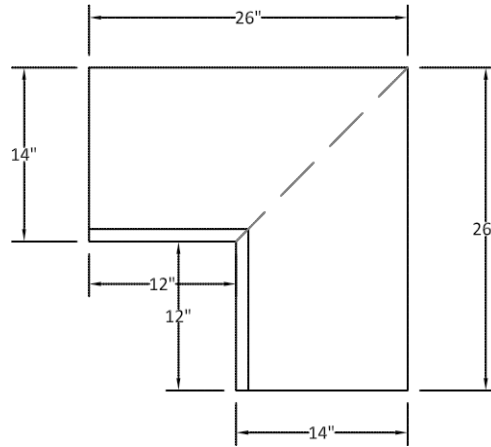

Outside Corner Transition

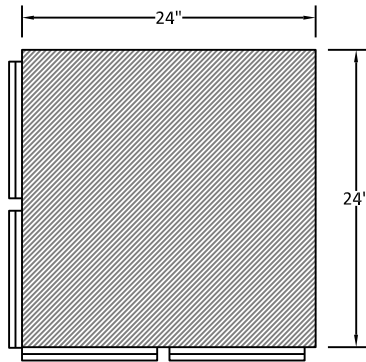

Top View

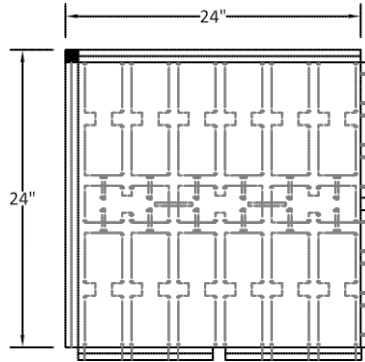

Bottom View



Side Views

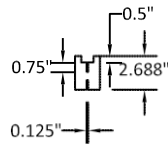

Side View

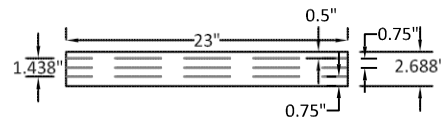

Front View

U Lock Section

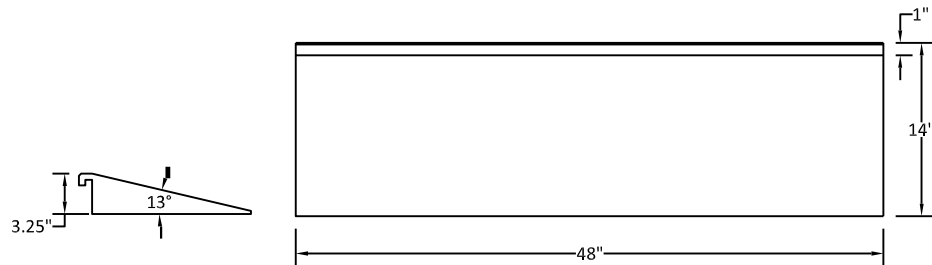

Ramp

